

PREPARED BY: DATE	<h1 style="text-align: center;">SHARP.</h1> <p style="text-align: center;">DISPLAY DEVICE BUSINESS DIVISION SHARP CORPORATION</p> <p style="text-align: center;"><b>SPECIFICATION</b></p>	SPEC No. LCY-1314302B
APPROVED BY: DATE		FILE No.
		ISSUE 04.Apr.2014
		PAGE 32 Pages
		APPLICABLE DIVISION DEVELOPMENT DEPARTMENT 2 DISPLAY DEVICE UNIT 1

DEVICE SPECIFICATION for  
 CGS Color LCD Module  
 (1440 × RGB × 2560 dots)

Model No.  
**LS055R1SX04**

CUSTOMER'S APPROVAL DATE

DATE \_\_\_\_\_

BY \_\_\_\_\_

PRESENTED BY 

HIDEHIKO YAMASHITA  
 Manager  
 DEVELOPMENT DEPARTMENT 2  
 DISPLAY DEVICE UNIT 1  
 DISPLAY DEVICE BUSINESS DIVISION  
 SHARP CORPORATION

More Display Panels On [www.panoxdiisplay.com](http://www.panoxdiisplay.com)

RECORDS OF REVISION			DOC. First issue	04.Apr.2014
			Model No.	LS055R1SX04
			Spec. No.	LCY—1314302B
DATE	REF.PAGE PARAGRAPH DRAWING No.	REVISED NO.	SUMMARY	
04.Apr.2014			First Issue	
09.May.2014	P.5	△ A	Mechanical Specification updated (Module Mass)	
	P.7		Current consumption modification	
	P.11		Circuit Diagrams modification (Addition of Resister on RESX-line)	
	P.12		Parts List modification (Addition of Resister on RESX-line)	
	P.13-P14		FPC Artwork modification (Addition of Resister on RESX-line)	
	P.23,26		To add Optical parameter (response time) Viewing angle condition changed	
	P.27-29		Packaging specifications updated	

More Display Panels On [www.PanelsDisplay.com](http://www.PanelsDisplay.com)

**NOTICE**

○ These specification sheets are the proprietary product of SHARP CORPORATION (SHARP) and include materials protected under copyright of SHARP. Do not reproduce or cause any third party to reproduce them in any form or by any means, electronic or mechanical, for any purpose, in whole or in part, without the express written permission of SHARP.

○ The application examples in these specification sheets are provided to explain the representative applications of the device and are not intended to guarantee any industrial property right or other rights or license you to use them. SHARP assumes no responsibility for any problems related to any industrial property right of a third party resulting from the use of the device.

○ The device listed in these specification sheets was designed and manufactured for use in Telecommunication equipment (terminals)

○ In case of using the device for applications such as control and safety equipment for transportation (aircraft, trains, automobiles, etc. ), rescue and security equipment and various safety related equipment which require higher reliability and safety, take into consideration that appropriate measures such as fail-safe functions and redundant system design should be taken.

○ Do not use the device for equipment that requires an extreme level of reliability, such as aerospace applications, telecommunication equipment (trunk lines), nuclear power control equipment and medical or other equipment for life support.

○ SHARP assumes no responsibility for any damage resulting from the use of the device which does not comply with the instructions and the precautions specified in these specification sheets.

○ Contact and consult with a SHARP sales representative for any questions about this device.

**[For handling and system design]**

(1) Do not scratch the surface of the polarizer film as it is easily damaged.

(2) If the cleaning of the surface of the LCD panel is necessary, wipe it swiftly with cotton or other soft cloth. Do not use organic solvent as it damages polarizer.

(3) Water droplets on polarizer must be wiped off immediately as they may cause color changes, or other defects if remained for a long time.

(4) Since this LCD panel is made of glass, dropping the module or banging it against hard objects may cause cracks or fragmentation.

(5) Certain materials such as epoxy resin (amine's hardener) or silicone adhesive agent (de-alcohol or de-oxym) emits gas to which polarizer reacts (color change). Check carefully that gas from materials used in system housing or packaging do not hurt polarizer.

(6) Liquid crystal material will freeze below specified storage temperature range and it will not get back to normal quality even after temperature comes back within specified temperature range. Liquid crystal material will become isotropic above specified temperature range and may not get back to normal quality. Keep the LCD module always within specified temperature range.

(7) Do not expose LCD module to the direct sunlight or to strong ultraviolet light for long time.

(8) If the LCD driver IC (COG) is exposed to light, normal operation may be impeded. It is necessary to design so that the light is shut off when the LCD module is mounted.

(9) Do not disassemble the LCD module as it may cause permanent damage.

(10) As this LCD module contains components sensitive to electrostatic discharge, be sure to follow the instructions in below.

① Operators

Operators must wear anti-static wears to prevent electrostatic charge up to and discharge from human body.

② Equipment and containers

Process equipment such as conveyer, soldering iron, working bench and containers may possibly generate electrostatic charge up and discharge. Equipment must be grounded through 100Mohms resistance. Use ion blower.

③ Floor

Floor is an important part to leak static electricity which is generated from human body or equipment.

There is a possibility that the static electricity is charged to them without leakage in case of insulating floor, so the counter measure (electrostatic earth:  $1 \times 10^8 \Omega$ ) should be made.

④ Humidity

Proper humidity of working room may reduce the risk of electrostatic charge up and discharge. Humidity should be kept over 50% all the time.

⑤ Transportation/storage

Storage materials must be anti-static to prevent causing electrostatic discharge.

⑥ Others

Protective film is attached on the surface of LCD panel to prevent scratches or other damages. When removing this protective film, remove it slowly under proper anti-ESD control such as ion blower.

(11) Hold LCD very carefully when placing LCD module into the system housing. Do not apply excessive stress or pressure to LCD module. Do not to use chloroprene rubber as it may affect on the reliability of the electrical interconnection.

(12) Do not hold or touch LCD panel to flex interconnection area as it may be damaged.

(13) As the binding material between LCD panel and flex connector mentioned in 12) contains an organic material, any type of organic solvents are not allowed to be used. Direct contact by fingers is also prohibited.

(14) When carrying the LCD module, place it on the tray to protect from mechanical damage. It is recommended to use the conductive trays to protect the CMOS components from electrostatic discharge. When holding the module, hold the Plastic Frame of LCD module so that the panel, COG and other electric parts are not damaged.

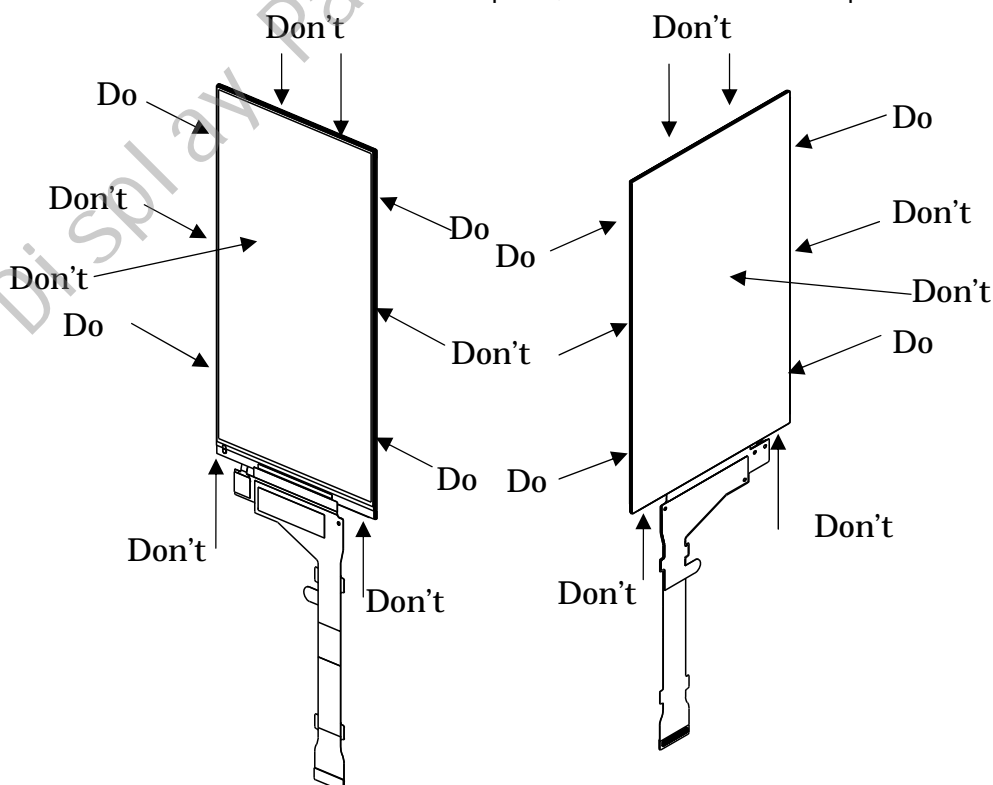

- (15) Do not touch the COG's patterning area. Otherwise the circuit may be damaged.
- (16) Do not touch LSI chips as it may cause a trouble in the inner lead connection.
- (17) Place a protective cover on the LCD module to protect the glass panel from mechanical damages.
- (18) LCD panel is susceptible to mechanical stress and even the slightest stress will cause a color change in background. So make sure the LCD panel is placed on flat plane without any continuous twisting, bending or pushing stress.
- (19) Protective film is placed onto the surface of LCD panel when it is shipped from factory. Make sure to peel it off before assembling the LCD module into the system. Be very careful not to damage LCD module by electrostatic discharge when peeling off this protective film. Ion blower and ground strap are recommended.
- (20) Make sure the mechanical design of the system in which the LCD module will be assembled matches specified viewing angle of this LCD module.
- (21) This LCD module does not contain nor use any ODS (1,1,1-Trichloroethane, CCL4) in all materials used, in all production processes.

#### [For operating LCD module]

- (1) Do not operate or store the LCD module under outside of specified environmental conditions.
- (2) At the shipment, adjust the contrast of each LCD module with electric volume. LCD contrast may vary from panel to panel depending on variation of LCD power voltage from system.
- (3) As opt-electrical characteristics of LCD will be changed, dependent on the temperature, the confirmation of display quality and characteristics has to be done after temperature is set at 25 °C and it becomes stable.

#### [Precautions for Storage]

- (1) Do not expose the LCD module to direct sunlight or strong ultraviolet light for long periods. Store in a dark place.
- (2) The liquid crystal material will solidify if stored below the rated storage temperature and will become an isotropic liquid if stored above the rated storage temperature, and may not retain its original properties. Only store the module at normal temperature and humidity (25±5°C,60±10%RH) in order to avoid exposing the front polarizer to chronic humidity.
- (3) Keeping Method
- Don't keeping under the direct sunlight.
  - Keeping in the tray under the dark place.

**DON'T**

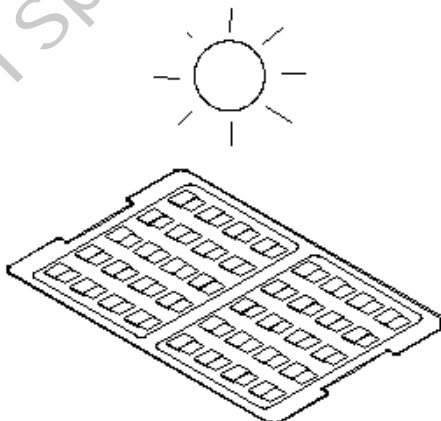

**DO**

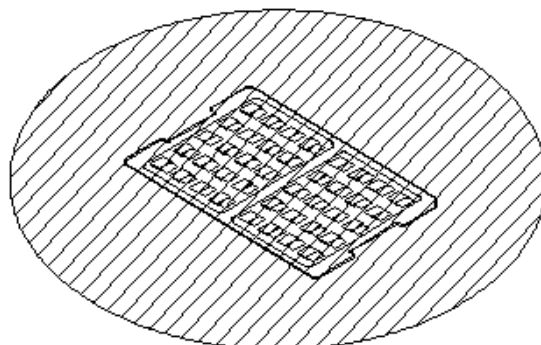

- (1) Do not operate or store the LCD module under outside of specified environmental conditions.
- (2) Be sure to prevent light striking the chip surface.

**[Other Notice]**

- (1) Do not operate or store the LCD module under outside of specified environmental conditions.
- (2) As electrical impedance of power supply lines (VDDIO-GND) are low when LCD module is working, place the de-coupling capacitor nearby LCD module as close as possible.
- (3) Reset signal must be sent after power on to initialize LSI. LSI does not function properly until initialize it by reset signal.
- (4) Generally, at power on, in order not to apply DC charge directly to LCD panel, supply logic voltage first and initialize LSI logic function including polarity alternation. Then supply voltage for LCD bias. At power off, in order not to apply DC charge directly to LCD panel, execute Power OFF sequence and Discharge command.
- (5) Don't touch to FPC surface, exposed IC chip, electric parts and other parts, to any electric, metallic materials.
- (6) No bromide specific fire-retardant material is used in this module.
- (7) Do not display still picture on the display over 2 hours as this will damage the liquid crystal.
- (8) The connector used in this LCD module is the one Sharp have not ever used. Therefore, please note that the quality of this connector concerned is out of Sharp's guarantee.
- (9) If the LCD module is kept under a high-humidity environment or it is used, the LCD module will curve. Be fully careful about the keeping constraints and production-process environment of the LCD module.
- (10) When you connect the LCD module to your set, or when you remove, please turn OFF the power supply of your set.
- (11) When you bend FPC, please perform the straight radius more than uniform  $\phi=0.6$ [mm].

**[Precautions for Discarding Liquid Crystal Modules]**

COG: After removing the LSI from the liquid crystal panel, dispose of it in a similar way to circuit boards from electronic devices.

LCD panel: Dispose of as glass waste. This LCD module contains no harmful substances. The liquid crystal panel contains no dangerous or harmful substances. The liquid crystal panel only contains an extremely small amount of liquid crystal (approx.100mg) and therefore it will not leak even if the panel should break.

-Its median lethal dose (LD50) is greater than 2,000 mg/kg and a mutagenetic (Aims test: negative) material is employed.

FPC: Dispose of as similar way to circuit board from electric device.

### 1. Application

This data sheet is to introduce the specification of LS055R1SX04 active matrix 16,777,216 color LCD module. Main color LCD module is controlled by Driver IC (R63419 with 1/3 RAM).

If any problem occurs concerning the items not stated in this specification, it must be solved sincerely by both parties after deliberation.

As to basic specification of driver IC refer to the IC specification and handbook.

### 2. Construction and Outline

Construction: LCD panel, Driver (COG), FPC with electric components, 14 White LED lumps, prism sheet, diffuser, light guide and reflector, plastic frame and Metal frame to fix them mechanically.

Outline: See page 31page

Connection: B to B connector (Japan Aviation Electronics Industry, Ltd, WP7B-P050VA1 50 pins, 0.4mm pitch)

There shall be no scratches, stains, chips, distortions and other external drawbacks that may affect the display function.

Rejection criteria shall be noted in Inspection Standard (IIS-TBD)

In order to realize thin module structure, double-sided adhesive tapes are used to fix LCD panels. As these tapes do not guarantee to permanently fix the panels, LCD panel may rise from the module when shipped from factory.

So please make sure to design the system to hold the edges of LCD panel by the soft material such as sponge when LCD module is assembled into the cabinet.

### 3. Mechanical Specification

Table 1

Item	Specifications	Unit	Remarks
Active area	68.04(H)X120.96(V)	mm	
Pixel format	1440(H)×2560(V)	Pixel	
	1 Pixel =R+G+B dots	-	
Pixel pitch	0.01575(H) x 0.04725(V)	mm	
Pixel configuration	R,G,B vertical stripes	-	
Display mode	Normally Black	-	
LDC Driving method	DC Driving / Column Inversion	-	
Liquid Crystal Mode	New Mode2	-	
Number of colors	16,777,216	Colors	24 bits
Outline dimensions	70.94(W)×128.49 (H)×1.35(D) TYP	mm	Note 3-1
Mass	Approx 25	g	

**Note 3-1) The above-mentioned table indicates module sizes without some projections and FPC.**

**For detailed measurements and tolerances, please refer to page 31.**

**4. Absolute Maximum Ratings**

(4-1) Electrical absolute maximum ratings

**Table 2**

Ta=25 °C

Parameter	Symbol	Min	Max	Unit	Remark
Supply Voltage	IOVCC-GND	-0.3	+4.6	V	*1
	VSP-GND	-0.3	+6.5	V	*1
	VSN-GND	-6.5	+0.3	V	*1

\*1: Voltage applied to GND pins. GND pin conditions are based on all the same voltage (0V).

Always connect all GND externally and use at the same voltage.

**Environment Conditions****Table 3**

Item	Top		Tstg		Remark
	MIN.	MAX.	MIN.	MAX.	
Ambient temperature	-20 °C	+60°C	-30 °C	+70°C	Note 2)
Humidity	Note 1)		Note 1)		No condensation

Note1) Ta ≤ 40 °C.....95 % RH Max

Note2) Ta &gt; 40 °C.....Absolute humidity shall be less than Ta=40 °C /95 % RH.

As opt-electrical characteristics of LCD will be changed, dependent on the temperature, the confirmation of display quality and characteristics has to be done after temperature is set at 25 °C and it becomes stable.

Be sure not to exceed the rated voltage, otherwise a malfunction may occur.

More Display Panels On WWW.PanoxdiSplay.com



## 5. Electrical Specifications

### (5-1) Electrical characteristics

Table 4

Ta=25 °C, GND=0V

Parameter	Symbol	Conditions	Min.	Typ.	Max.	Unit	Applicable Pin
Supply voltage1	IOVCC-GND	Ta=-20~60 °C	1.7	1.8	1.9	V	(note 1)
Supply voltage2	VSP-GND	Ta=-20~60 °C	5.60	5.75	5.90	V	(note 1)
Supply voltage3	VSN-GND	Ta=-20~60 °C	-5.90	-5.75	-5.60	V	(note 1)
"H" level input voltage	V <sub>IH</sub>	Ta=-20~60 °C	0.7 IOVCC	-	IOVCC	V	(note 2)
"L" level input voltage	V <sub>IL</sub>		0	-	0.3IOVCC	V	
"H" level Input current	I <sub>IH</sub>	Ta=-20~60 °C	-	-	10	μA	
"L" level Input current	I <sub>IL</sub>		-10	-	-	μA	
"H" level Output voltage	V <sub>OH</sub>	Ta=-20~60 °C	0.8 IOVCC	-	IOVCC	V	I <sub>OH</sub> =-0.1mA
"L" level Output voltage	V <sub>OL</sub>		-	-	0.2 IOVCC	V	I <sub>OL</sub> =+0.1mA
MIPI high speed mode							
Common mode voltage High Speed receive mode	VCMRX(DC)	Ta=-20~60 °C	70	-	330	mV	(note 3)
Differential input high threshold voltage	VIDTH	Ta=-20~60 °C	-	-	70	mV	(Note 3)
Differential input low threshold voltage	VIDTL	Ta=-20~60 °C	-70	-	-	mV	(Note 3)
Single-ended input high voltage	VIHHS	Ta=-20~60 °C	-	-	460	mV	(Note 3)
Single-ended input low voltage	VILHS	Ta=-20~60 °C	-40	-	-	mV	(Note 3)
MIPI LP mode							
Logic High level input voltage	VIH	Ta=-20~60 °C	880	-	1350	mV	(Note 3)
Logic Low level input voltage	VIL	Ta=-20~60 °C	-50	-	550	mV	(Note 3)
Logic High level output voltage	VOH	Ta=-20~60 °C	1.1	1.2	1.3	V	(Note 3)
Logic Low level output voltage	VOL	Ta=-20~60 °C	-50	-	50	mV	(Note 3)
Logic 0 contention threshold	VILCD	Ta=-20~60 °C	-	-	200	mV	(Note 3)
Logic 1 contention threshold	VIHCD	Ta=-20~60 °C	450	-	-	mV	(Note 3)
 Current consumption	Iiofcc1	Ta=25 °C	-	23.5	32.9	mA	(note 4)
	Ivsp1	Ta=25 °C	-	15	21	mA	(note 4)
	Ivsn1	Ta=25 °C	-	14	19.6	mA	(note 4)

(Note 1) Include Ripple Noise

(Note 2) Applied overshoot

(Note 3)  $V_{CMRX(DC)} = (V_P + V_{DN})/2$ ;

Minimum 110mV/-110mV HS differential swing is required for display data transfer.

(Note 4) Measurement conditions: Ta=25°C Full screen white pattern, VSP=5.75V/VSN=-5.75V/IOVCC=1.8V, 60Hz Refresh

(5-2) LED back light

(1) At main panel the back light uses 16pcs edge light type white LED.

Table 5

Parameter	Conditions	Symbol	Min.	Typ.	Max.	Unit	Remark
Forward current	Ta=25 °C	I <sub>LED</sub>	-	20*1	-	mA	LEDA LEDC1-/LEDC2-

LED lamp: NSSW304D (NICHIA)

\*1 per one piece of LED

\*Please consider Allowable Forward Current on used temperature  
(refer to Ambient Temperature vs. Allowable Forward Current curve)

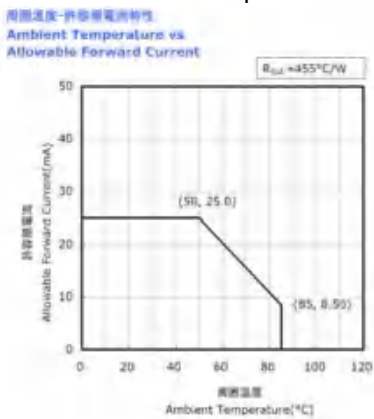

Fig.1 LED Characteristic(De-rating Curve)

(1) Absolute Maximum Ratings

Item	Symbol	Absolute Maximum Rating	Unit
Forward Current	I <sub>F</sub>	25	mA
Pulse Forward Current	I <sub>FP</sub>	80	mA
Reverse Voltage	V <sub>R</sub>	5	V
Power Dissipation	P <sub>D</sub>	82.5	mW
Operating Temperature	T <sub>OPR</sub>	-30~85	°C
Storage Temperature	T <sub>STG</sub>	-40~100	°C
Junction Temperature	T <sub>J</sub>	105	°C

\* Absolute Maximum Ratings at T<sub>A</sub>=25°C.

\* I<sub>FP</sub> conditions with pulse width ≤10ms and duty cycle ≤10%.

(2) Initial Electrical/Optical Characteristics

Item	Symbol	Condition	Typ	Max	Unit
Forward Voltage	V <sub>F</sub>	I <sub>F</sub> =20mA	3.0	-	V
Reverse Current	I <sub>R</sub>	V <sub>R</sub> =5V	-	-	μA
Luminous Flux (Chromaticity Coordinate1)	Φ <sub>v</sub>	I <sub>F</sub> =20mA	8.0	-	lm
Luminous Intensity (Chromaticity Coordinate1)	I <sub>v</sub>	I <sub>F</sub> =20mA	2.55	-	cd
Chromaticity Coordinate1	x	I <sub>F</sub> =20mA	0.300	-	-
	y	I <sub>F</sub> =20mA	0.295	-	-
Luminous Flux (Chromaticity Coordinate2)	Φ <sub>v</sub>	I <sub>F</sub> =20mA	7.65	-	lm
Luminous Intensity (Chromaticity Coordinate2)	I <sub>v</sub>	I <sub>F</sub> =20mA	2.4	-	cd
Chromaticity Coordinate2	x	I <sub>F</sub> =20mA	0.290	-	-
	y	I <sub>F</sub> =20mA	0.275	-	-
Thermal Resistance	R <sub>θjF</sub>	-	120	180	°C/W

\* Characteristics at T<sub>A</sub>=25°C.

\* Luminous Flux value as per CIE 127:2007 standard.

\* Chromaticity Coordinates as per CIE 1931 Chromaticity Chart.

\* R<sub>θjF</sub> is Thermal Resistance from junction to T<sub>F</sub> measuring point.

(5-3) Interface signals

Table 6

Pin No	Symbol	Description	I/O	Remarks
1	GND	Ground	-	
2	GND	Ground	-	
3	VSN	Power supply for analog(-5.75V)	-	
4	VSP	Power supply for analog(+5.75V)	-	
5	HSYNC	Horizontal Synchronizing signal	O	
6	GND	Ground	-	
7	GND	Ground	-	
8	DSI_A_D3-	MIPI DSI(-) of Port A	I	
9	DSI_A_D0-	MIPI DSI(-) of Port A	I/O	
10	DSI_A_D3+	MIPI DSI(+) of Port A	I	
11	DSI_A_D0+	MIPI DSI(+) of Port A	I/O	
12	GND	Ground	-	
13	GND	Ground	-	
14	DSI_A_CLK-	MIPI DSI Clock (-) of PortA	I	
15	DSI_A_D1-	MIPI DSI (-) of PortA	I	
16	DSI_A_CLK+	MIPI DSI Clock (+) of PortA	I	
17	DSI_A_D1+	MIPI DSI (+) of PortA	I	
18	GND	Ground	-	
19	GND	Ground	-	
20	DSI_A_D2-	MIPI DSI (-) of PortA	I	
21	DSI_B_D2+	MIPI DSI (+) of PortB	I	
22	DSI_A_D2+	MIPI DSI (+) of PortA	I	
23	DSI_B_D2-	MIPI DSI (-) of PortB	I	
24	GND	Ground	-	
25	GND	Ground	-	
26	DSI_B_D1+	MIPI DSI (+) of PortB	I	
27	DSI_B_CLK+	MIPI DSI Clock (+) of PortB	I	
28	DSI_B_D1-	MIPI DSI (-) of PortB	I	
29	DSI_B_CLK-	MIPI DSI Clock (-) of PortB	I	
30	GND	Ground	-	
31	GND	Ground	-	
32	DSI_B_D0+	MIPI DSI (+) of PortB	I/O	
33	DSI_B_D3+	MIPI DSI (+) of PortB	I	
34	DSI_B_D0-	MIPI DSI (-) of PortB	I/O	
35	DSI_B_D3-	MIPI DSI (-) of PortB	I	
36	GND	Ground	-	
37	GND	Ground	-	
38	RESX	Device reset signal	I	"L" Active
39	IOVCC	Power supply for I/O	-	
40	TE	Tearing signal output from driver IC	O	
41	IOVCC	Power supply for I/O	-	
42	GND	Ground	-	
43	GND	Ground	-	
44	LED_PWM	Control signal for brightness of LED backlight	O	
45	ID1	ID1(connect to VDDI in FPC)	-	
46	ID2	ID2(connect to VDDI in FPC)	-	
47	LED1-	LED back light power negative1 (group1)	-	
48	LED+	LED back light power positive	-	
49	LED2-	LED back light power negative1 (group2)	-	
50	NC	No connect	-	

Mounted connector : 50pins; 0.4mm pitch; B to B connector. (JAE : WP7B-P050VA1)  
 Corresponded connector : 50pins; 0.4mm pitch; B to B connector. (JAE : WP7B-S050VA1)  
 Signals connect to LCD module. Symbols correspond able to Circuit diagram in Page 11.

(5-4) Schematic of LCD module system

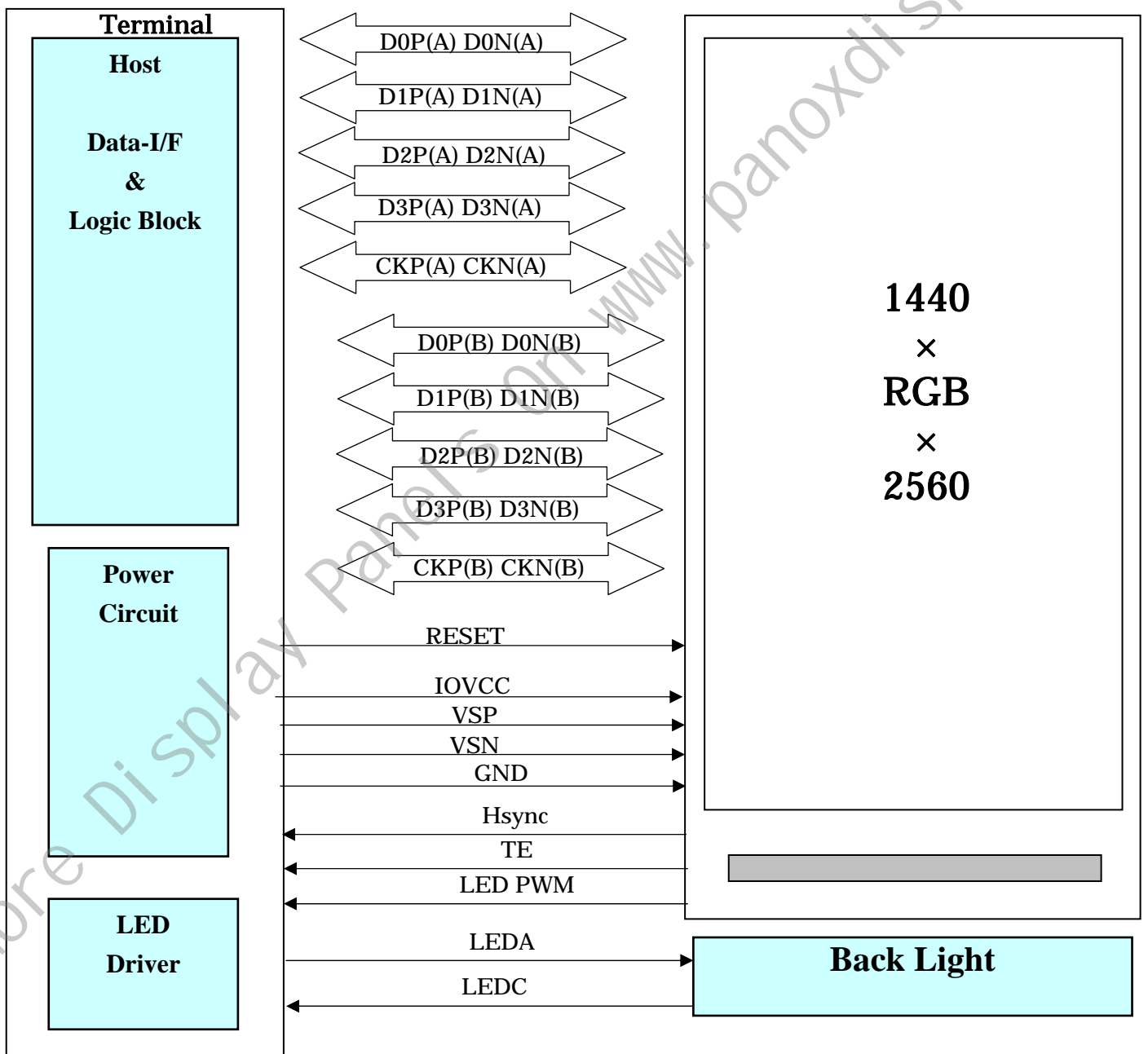

Fig.2 Schematic of LCD module system

(5-5) Circuit Diagrams

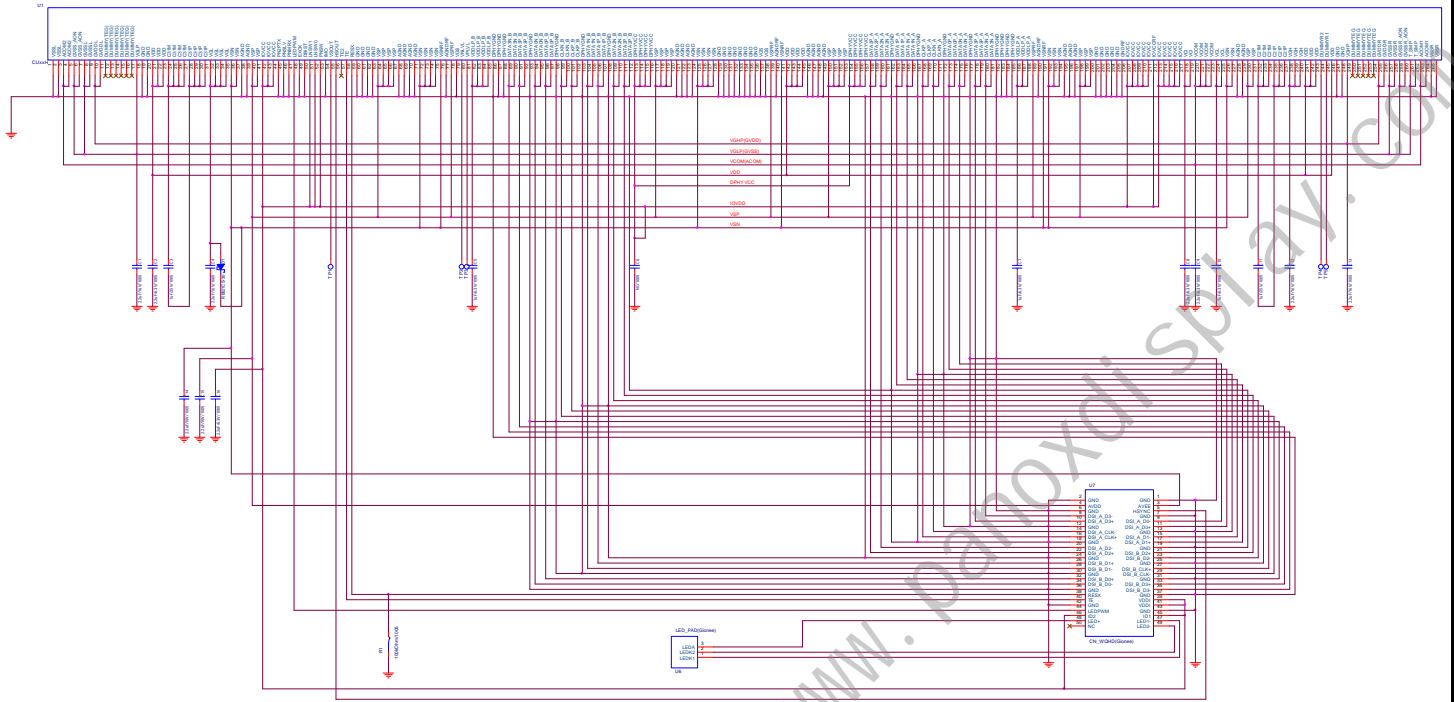

Fig.3 Circuit diagram

## (5-6) Parts List

Table 7

Category	Ref. No.	Spec			Vendor
Capacitor	C1	2.2uF	16V	1005	Multi Vendor
	C2	2.2uF	6.3V	1005	Multi Vendor
	C3	1.0uF	25V	1005	Multi Vendor
	C4	2.2uF	16V	1005	Multi Vendor
	C5	1.0uF	6.3V	1005	Multi Vendor
	C7	1.0uF	6.3V	1005	Multi Vendor
	C8	2.2uF	6.3V	1005	Multi Vendor
	C9	2.2uF	6.3V	1005	Multi Vendor
	C10	1.0uF	6.3V	1005	Multi Vendor
	C11	1.0uF	25V	1005	Multi Vendor
	C12	2.2uF	16V	1005	Multi Vendor
	C13	2.2uF	16V	1005	Multi Vendor
	C14	2.2uF	10V	1005	Multi Vendor
	C15	2.2uF	10V	1005	Multi Vendor
	C16	2.2uF	6.3V	1005	Multi Vendor
	Diode	D1	VF<0.4V VR $\geq$ max.25V		
Connector	CN	0.4mm pitch / 50Pin			JAE
Resister	R1	100kOhm/1005/0.063W			Multi Vendor

More Display Panels On [www.leddisplay.com](http://www.leddisplay.com)

(5-7)FPC Artwork

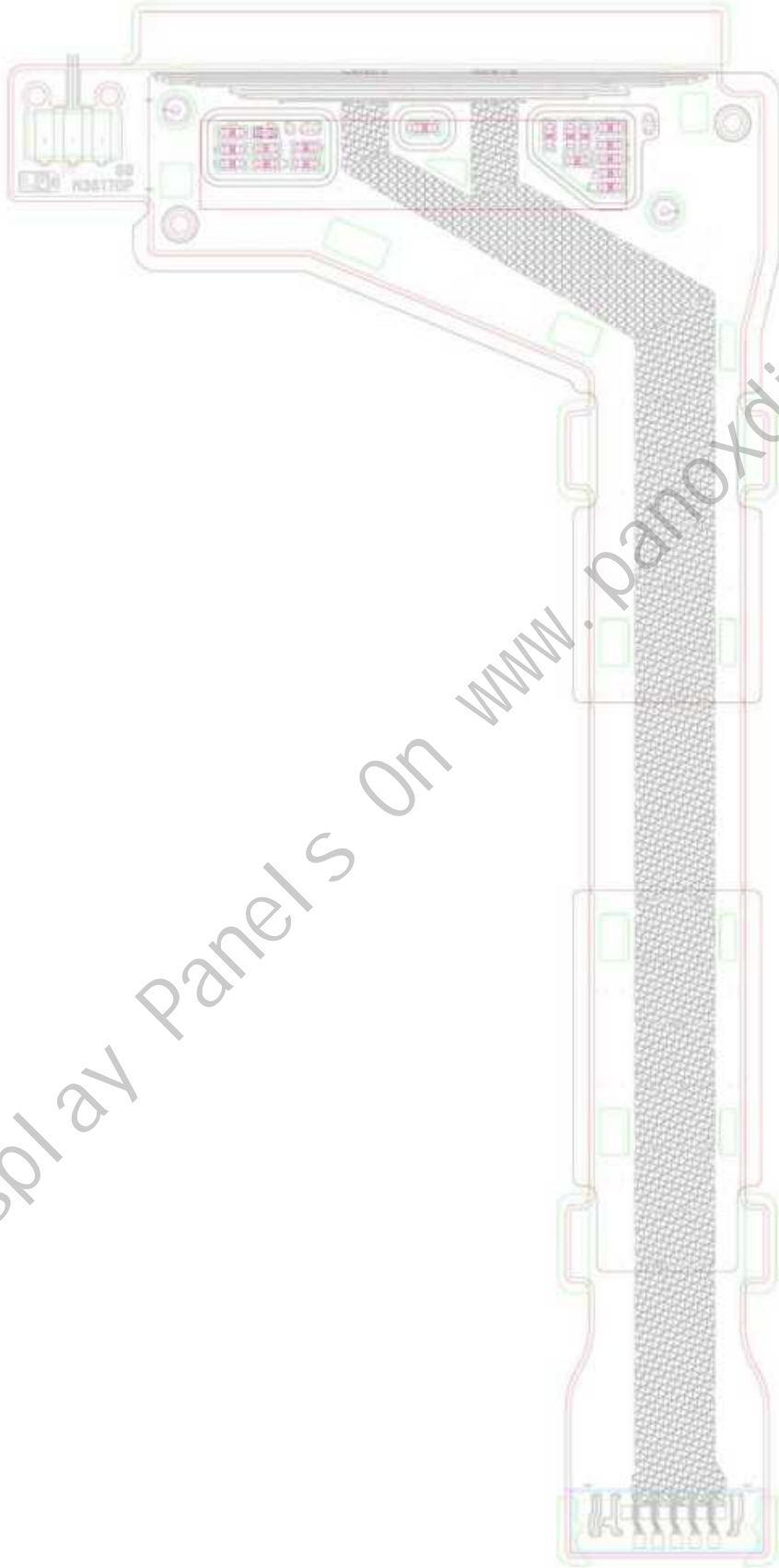

Fig. 4 Layer 1



Fig. 5 Layer 2

More Display Panels On [www.panoxdisplay.com](http://www.panoxdisplay.com)



## 6. Timing characteristics of input signals

### (6-1) MIPI DC/AC Characteristics

#### <DC characteristics>

Table 8

Ta=+25°C, GND=0V

Item	Symbol	Unit	Test condition	Min.	Typ.	Max.	Note	
HS-RX	Differential input high threshold	VIDTH	mV	IOVDD=1.65V~3.30V	-	-	70	2
	Differential input low threshold	VIDTL	mV	IOVDD=1.65V~3.30V	-70	-	-	2
	Single-ended input low voltage	VILHS	mV	IOVDD=1.65V~3.30V	-40	-	-	
	Single-ended input high voltage	VIHHS	mV	IOVDD=1.65V~3.30V	-	-	460	
	Common-mode voltage HS receive mode	VCMRX(DC)	mV	IOVDD=1.65V~3.30V	70	-	330	1
	Differential input impedance	ZID	Ω	IOVDD=1.65V~3.30V	-	100	-	
LP-RX	Logic 0 input voltage not in ULP State	VIL	mV	IOVDD=1.65V~3.30V	-50	-	550	
	Logic 1 input voltage	VIH	mV	IOVDD=1.65V~3.30V	880	-	1350	
	I/O leakage current	ILEAK	μA	Vin = -50mV - 1350mV	-10	-	10	
LP-TX	Thevenin output low level	VOL	mV	IOVDD=1.65V~3.30V	-50	-	50	
	Thevenin output high level	VOH	V	IOVDD=1.65V~3.30V	1.1	1.2	1.3	
	Output impedance of LP transmitter	ZOLP	Ω	IOVDD=1.80V	110	-	-	
CD-RX	Logic 0 contention threshold	VILCD	mV	IOVDD=1.65V~3.30V	-	-	200	
	Logic 1 contention threshold	VIHCD	mV	IOVDD=1.65V~3.30V	450	-	-	

Notes: 1. VCMRX (DC) = (VP+VDN)/2

2. Minimum 110mV/-110mV HS differential swing is required for display data transfer.

<AC Characteristics>

Table 9

Ta=+25°C, GND=0V

Item	Symbol	Unit	Test condition	Min.	Typ.	Max.	Note
DSICLK Frequency	fDSICLK	MHz	IOVCC=1.65V~3.30V DPHYVCC=1.65V~3.30V	100	-	500	1
DSICLK Cycle time	tCLKP	ns	IOVCC=1.65V~3.30V DPHYVCC=1.65V~3.30V	1	-	10	
DSI Data Transfer Rate	tDSIR	Mbps	IOVCC=1.65V~3.30V DPHYVCC=1.65V~3.30V DSI 2 lanes, 3 lanes, 4lane	200	-	1000	1
Data to Clock Setup Time	tSETUP	UI	IOVCC=1.65V~3.30V DPHYVCC=1.65V~3.30V	0.15	-	-	3
		ns	IOVCC=1.65V~3.30V DPHYVCC=1.65V~3.30V	0.15	-	-	2,3
Clock to Data Hold Time	tHOLD	UI	IOVCC=1.65V~3.30V DPHYVCC=1.65V~3.30V	0.15	-	-	3
		ns	IOVCC=1.65V~3.30V DPHYVCC=1.65V~3.30V	0.15	-	-	2,3

- Notes:
1. When fDSICLK<125MHz, change auto load NV setting so that it is compliant with THS-PREPARE+THS-ZERO spec.
  2. Minimum tSETUP/tHOLD Time is 0.15UI. This value may change according to DSI transfer rate.
  3. tSETUP/tHOLD Time are measured without HS-TX Jitter.

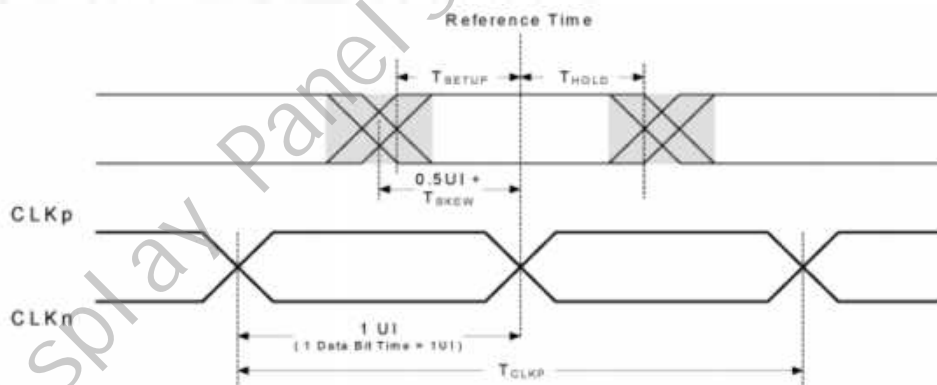

## (6-2) Reset Timing Characteristics

Table 10

Ta=+25°C, GND=0V

Item	Symbol	Unit	Test condition	Min.	Max.
Reset low-level width1	tRW1	μs	Power supply on	1000	—
Reset low-level width2	tRW2	μs	Operation	1000	—
Reset time (Sleep IN)	tRT1	ms	—	—	3
Reset time (Sleep OUT)	tRT2	ms	—	—	3
Noise reject width	tRESNR	μs	—	—	1

### (1) Reset Reject

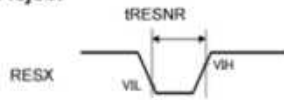

### (2-a) Reset timing at power supply on

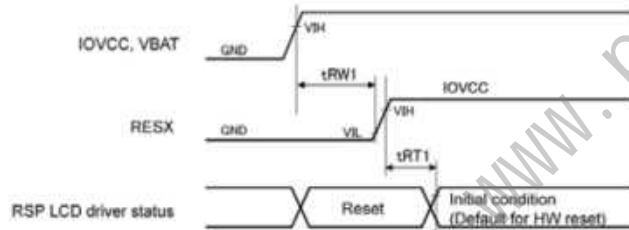

### (2-b) Reset timing during operation (sleep in)

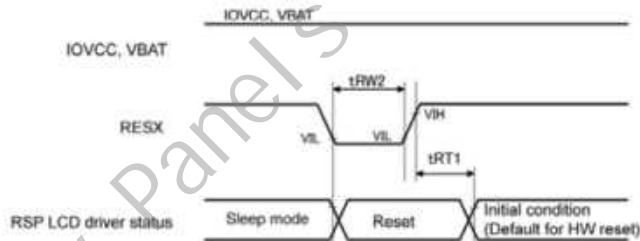

### (2-c) Reset timing during operation (sleep out)

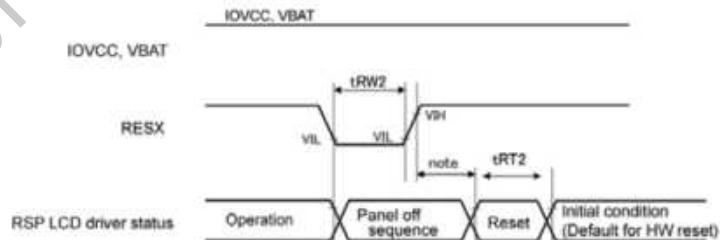
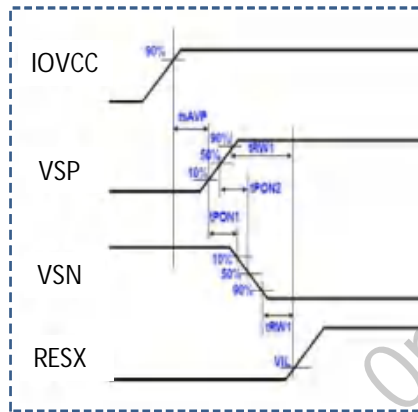
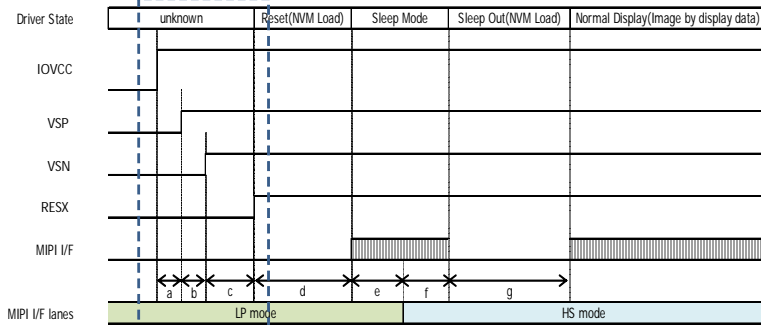

Fig .6 Reset timing characteristics

## 7. Initial Sequence

### (7-1) Power On Sequence (command mode)



Item	Symbol	min
VSP to VSN delay time (10% to 10%)	tPON1	0ms
VSP to VSN delay time (50% to 50%)	tPON2	0ms
System power on to VSP ON time	tsAVP	1ms
Reset low-level width	tRW1	1ms

### <Command mode>

Recommended Power On Sequence							term	
Step	Address	Parameter	Data	DS1 data type	Delay	Command		
1	Initial condition						RESX = L	
2	Power Supply IOVCC (Typ1.8V)						IOVCC ON	
3	Wait						tsAVP	a.
4	Power Supply VSP (Typ5.75V)						VSP ON	
5	Wait						tPON1/tPON2	b.
6	Power Supply VSN (Typ-5.75V)						VSN ON	
7	Wait						tRW1	c.
8	RESET High						RESX = H	
9	Wait						Min.10 ms	d.
10							[Automatic] Sleep Mode On	
11	0xB0	P1	00h	Generic	29h	The command to unlock manufacturing command write (CABC, CE etc.)	e.	
	0xD6	P1	01h	Generic	29h	The command to remove NVM reload after sleep out.		
	0xB3	P1	08h	Generic	29h	MIPI Command mode=08h		
	0x51	P1	FFh	DCS	39h	Display Brightness = 100%		
	0x53	P1	0Ch	DCS	39h	LED PWM output enable / Dimming function ON		
	0x35	P1	00h	DCS	39h	TE enable		
	0x2A	P1	00h	DCS	39h	start Column address : 000h		
	P2	00h			end Column address : 59Fh (1439)			
	P3	05h						
	P4	9Fh						
If customer need, please add initial command in here.								
	0xB0	P1	03h	Generic	29h	The command to lock manufacturing command write		
12	Display data transfer						Image Write	
13	0x29	-	-	DCS	39h	Display On	f.	
14	0x11	-	-	DCS	39h	Sleep Out		
15	Wait						Min.6 frame	
16							[Automatic] Sleep Mode Off/Display On	g.

Table 11-1

## (7-2) Power On Sequence (Video mode)

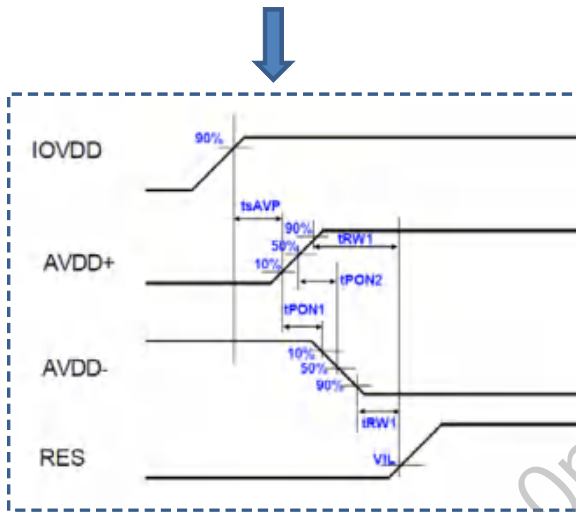
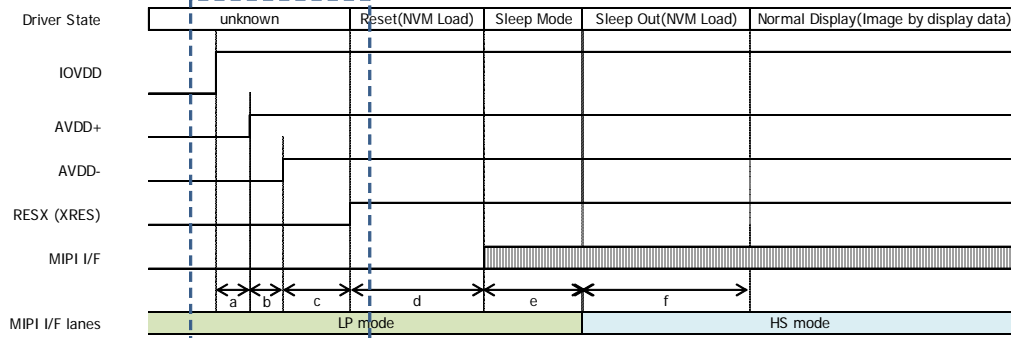

Item	Symbol	min
AVDD+ to AVDD- delay time (10% to 10%)	tPON1	0ms
AVDD+ to AVDD- delay time (50% to 50%)	tPON2	0ms
System power on to AVDD+ ON time	tsAVP	1ms
Reset low-level width	tRW1	1ms

### <Video mode>

Recommended Power On Sequence							term
Step	Address	Parameter	Data	DSI data type		Delay	Command
1	Initial condition						XRES = L
2	Power Supply IOVDD (Typ1.8V)						IOVDD ON
3	Wait					tsAVP	Wait until power stable
4	Power Supply AVDD+ (Typ5.75V)						AVDD+ ON
5	Wait					tPON1/tPON2	
6	Power Supply AVDD- (Typ-5.75V)						AVDD- ON
7	Wait					tRW1	
8	RESX High						XRES = H
9	Wait					Min.10 ms	[Automatic] NVM Auto load
10							[Automatic] Sleep Mode On
11	0xB0	P1	00h	Generic	29h		The command to unlock manufacturing command write (CABC, CE etc.)
	0xD6	P1	01h	Generic	29h		The command to remove NVM reload after sleep out.
	0xB3	P1	18h	Generic	29h		MIPI Video through mode=18h
	0x51	P1	FFh	DCS	39h		Display Brightness = 100%
	0x53	P1	0Ch	DCS	39h		LED PWM output enable / Dimming function ON
	0x35	P1	00h	DCS	39h		TE enable
	If customer need, please add initial command in here.						
	0xB0	P1	03h	Generic	29h		The command to lock manufacturing command write
12	0x29	-	-	DCS	39h		Display On
13	0x11	-	-	DCS	39h		Sleep Out
14	Host Display Data transfer						
15	Wait					Min.6 frame	Image Write(Send Video Stream Packet)
16							[Automatic] Sleep Mode Off/Display On

Table 11-2

### (7-3) Power Off Sequence(Command mode)

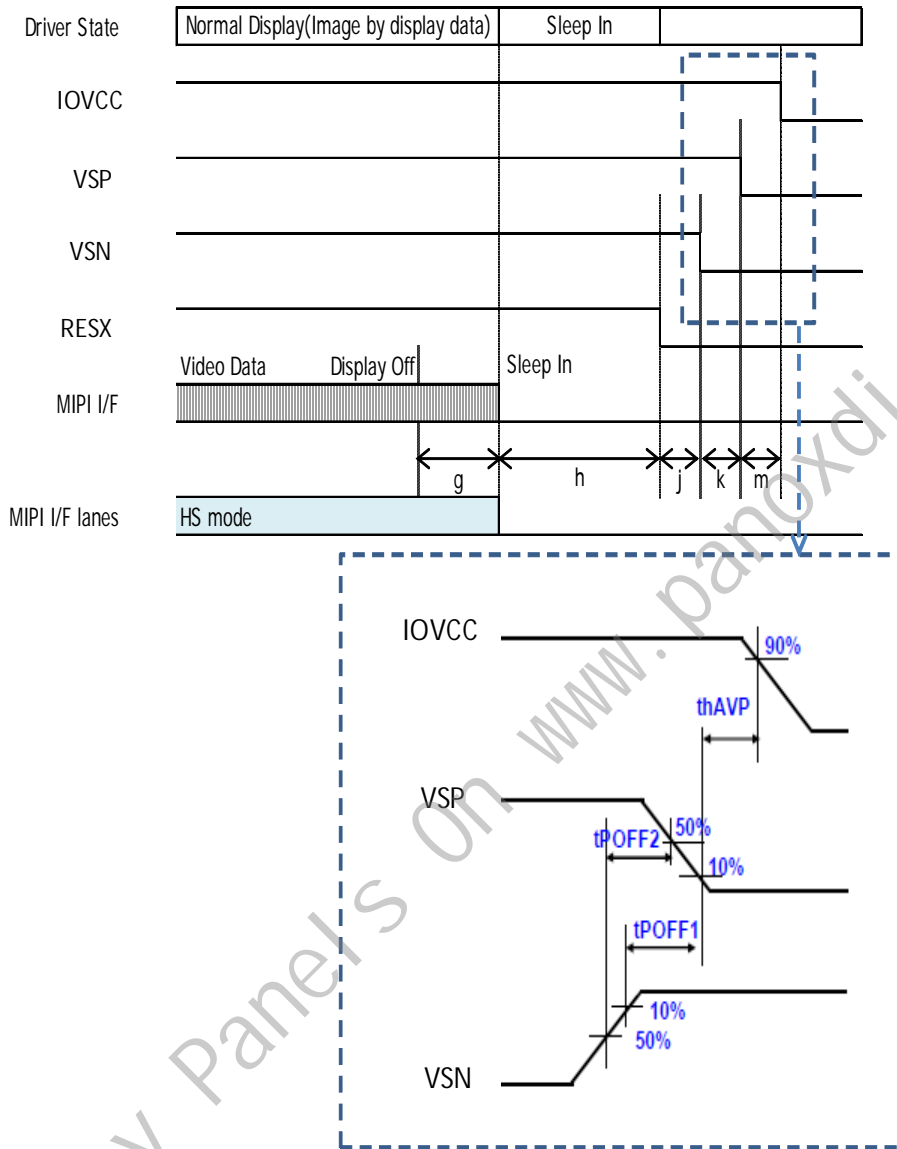

Item	Symbol	Min
VSN to VSP delay time (10% to 10%)	tPOFF1	0ms
VSN to VSP delay time (50% to 50%)	tPOFF2	0ms
VSP off to system power off time	thAVP	100ms

#### <Command mode>

Recommended Power Off Sequence							
Step	Address	Parameter	Data	DSI data type	Delay	Command	term
1	28h	-	-	DCS	39h	Display Off	
2	Wait				Min. 1 frame		g
3	10h	-	-	DCS	39h	Sleep In	
4	Wait				Min. 4frame		h
5	RESET Low					RESX = L	
6	Wait				Min.0ms		j
7	VSN(Typ-5.75V) OFF						
8					tPOFF1/tPOFF2	Wait	k
9	VSP(Typ+5.75V) OFF						
10					thAVP	Wait	m
11	IOVCC OFF(Typ1.8V) OFF						

Table 12-1

### (7-4) Power Off Sequence(Video mode)

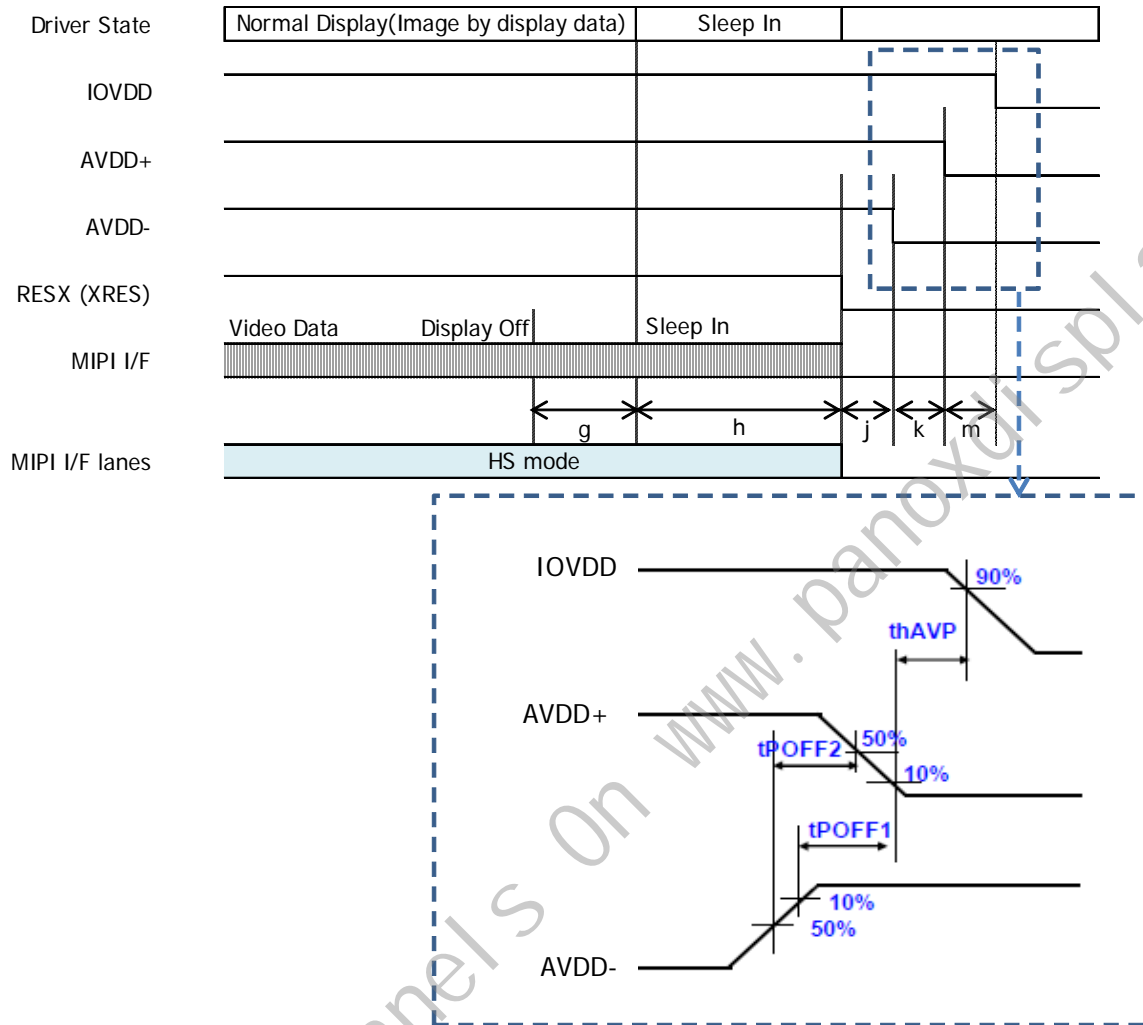

Item	Symbol	Min
AVDD- to AVDD+ delay time (10% to 10%)	tPOFF1	0ms
AVDD- to AVDD+ delay time (50% to 50%)	tPOFF2	0ms
AVDD+ off to system power off time	thAVP	100ms

#### <Video mode>

Recommended Power Off Sequence								
Step	Address	Parameter	Data	DSI data type		Delay	Command	term
1	28h	-	-	DCS	39h		Display Off	g
2	Wait					Min.1 frame		
3	10h	-	-	DCS	39h		Sleep In	h
4	Wait					Min. 4frame	Hsync/Vsync signals should be send after Sleep In command	
5							Mipi data transfer Stop	
6	RESX Low						XRES = L	
7	Wait					Min.0ms		j
8	AVDD-(Typ-5.75V) OFF							k
9						tPOFF1/tPOFF2	Wait	
10	AVDD+(Typ+5.75V) OFF							
11						thAVP	Wait	m
12	IOVDD OFF(Typ1.8V) OFF							

Table 12-2

## 8. Mipi Video Setting

Condition  
 • DSI 4Lane, 2port  
 • 850Mbps/Lane

### Vertical Display Timing

Item	Symbol	Condition	Unit	Value
Vertical cycle	VP		Line	2568
Vertical low pulse width	VS		Line	1
Vertical front porch	VFP		Line	4
Vertical back porch	VBP		Line	3
Vertical data start point	-	BP	Line	4
vertical blanking period	VBL	VFP+BP	Line	8
Vertical active area	Vadr		Line	2560

### Horizontal Display Timing

Item	Symbol	Condition	Unit	Value
Horizontal front porch	HFP		ByteClock	100
Horizontal data start point	-	HS+HBP	ByteClock	46
Horizontal active area	Hadr		Pixel	1440

Frame Frequency:60.3Hz

### Display Timing

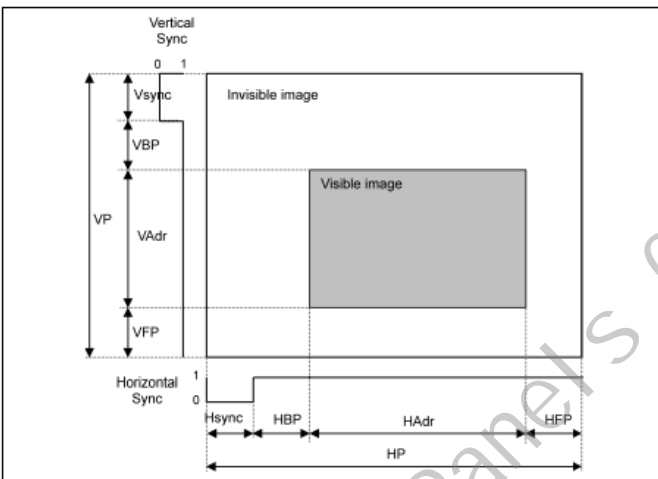

### Vertical Display Timing

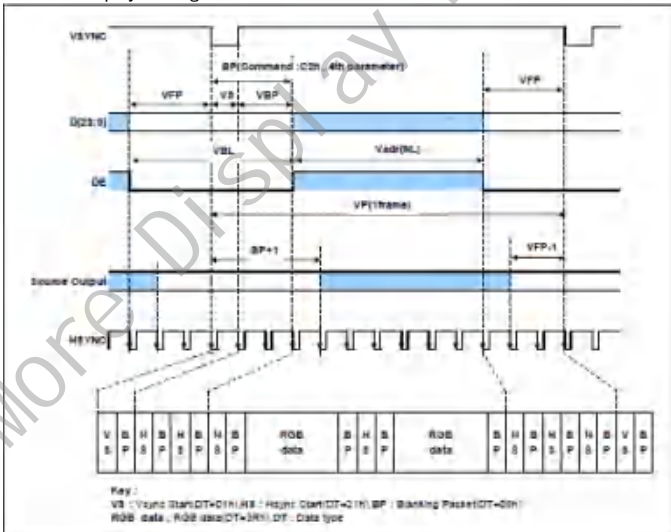

### Horizontal Display Timing

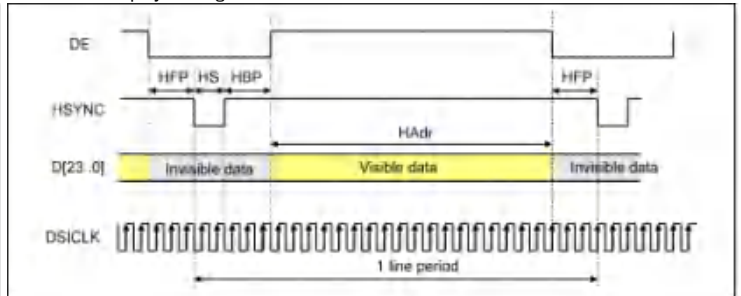

Table 13



## 9. Optical Characteristics

Table 14

IOVCC=1.8V, VSP=5.75V, VSN=-5.75V, ILED=20mA/pcs, Ta = 25°C

### Optical Characteristics

Parameter	symbol	condition	MIN	TYP	MAX	unit	Remark
Brightness	Br	$\theta=0^\circ$	315	450	-	cd/m <sup>2</sup>	Note1,2
<b>Response Time</b>	<b><math>\tau_r + \tau_d</math></b>	<b><math>\theta=0^\circ</math></b>			<b>35</b>	<b>ms</b>	<b>Note5</b>
Contrast	Co	$\theta=0^\circ$	900	1300	-		Note1,3
Viewing Angle	$\theta_{11}$	<b>Co &gt; 10</b>	70	80	-	deg	Note1
	$\theta_{12}$		70	80	-		
	$\theta_{21}$		70	80	-		
	$\theta_{22}$		70	80	-		
White chromaticity	x	$\theta=0^\circ$	0.27	0.30	0.33		Note.1,3
	y		0.29	0.32	0.35		
Red chromaticity	x	$\theta=0^\circ$	0.62	0.65	0.68		
	y		0.31	0.34	0.37		
Green chromaticity	x	$\theta=0^\circ$	0.28	0.31	0.34		
	y		0.58	0.61	0.64		
Blue chromaticity	x	$\theta=0^\circ$	0.13	0.16	0.19		
	y		0.04	0.07	0.10		
Uniformity	-	$\theta=0^\circ$	70	-	-	%	Note.4
NTSC ratio	-	$\theta=0^\circ$		70	-	%	Note.1,3

More Display Panels on www.panoxdi.com

Note 1) Definition of range of visual angle

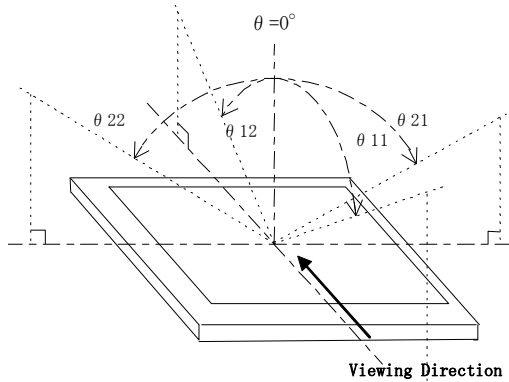

Fig. 7 Definition of viewing angle

Note 2) Brightness is measured as shown in Fig.5, and is defined as the brightness of all pixels "White" at the center of display area on optimum contrast.

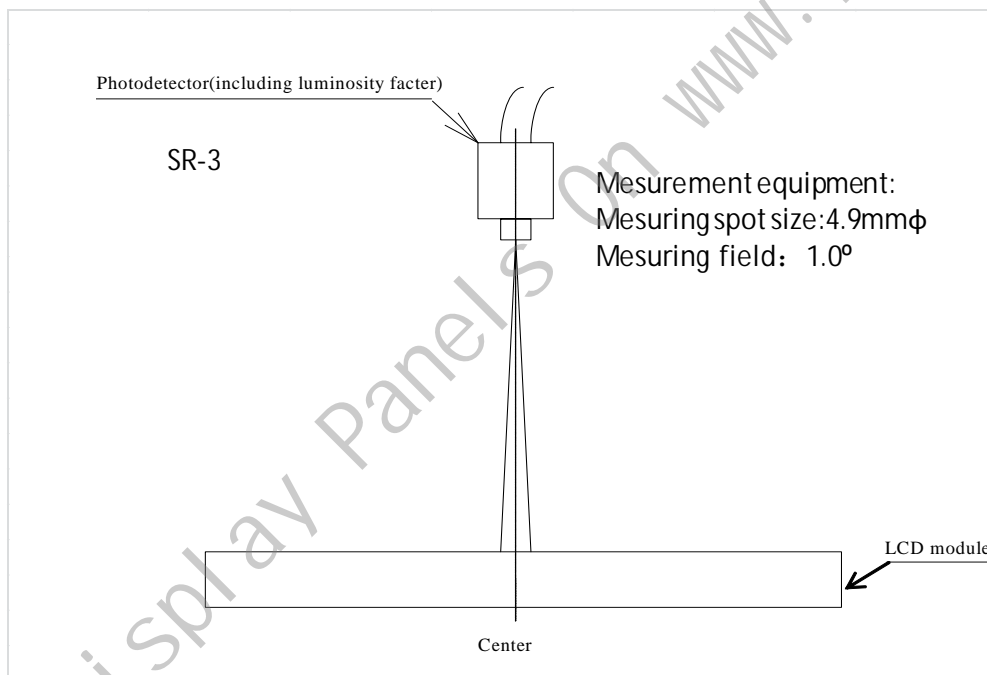

Fig. 8 Optical characteristics Test Method (Brightness)

Note 3) Contrast ratio is defined as follows:

$$Co = \frac{\text{Luminance(brightness) all pixels "White"}}{\text{Luminance(brightness) all pixels "Black"}}$$

Note 4) Uniformity is defined as follows:

$$\text{Uniformity} = \frac{\text{Minimum Luminance(brightness) in 9 points}}{\text{Maximum Luminance(brightness) in 9 points}}$$

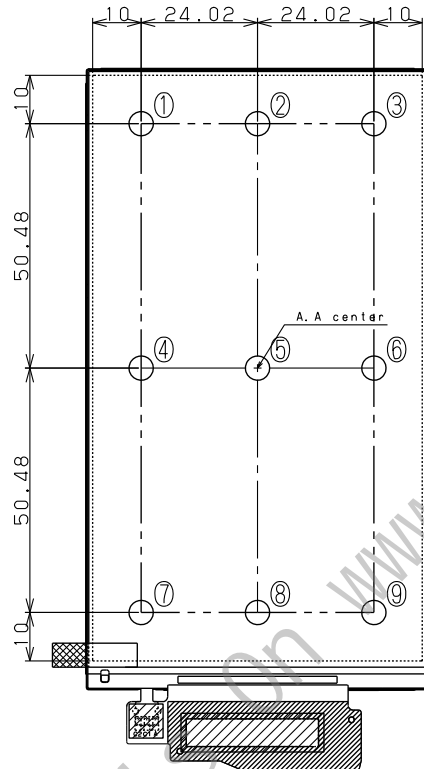

Fig. 9 Measuring Point

Note 5) Definition of response time:

The response time is defined as the following figure and shall be measured by switching the input signal for "black" and "white"

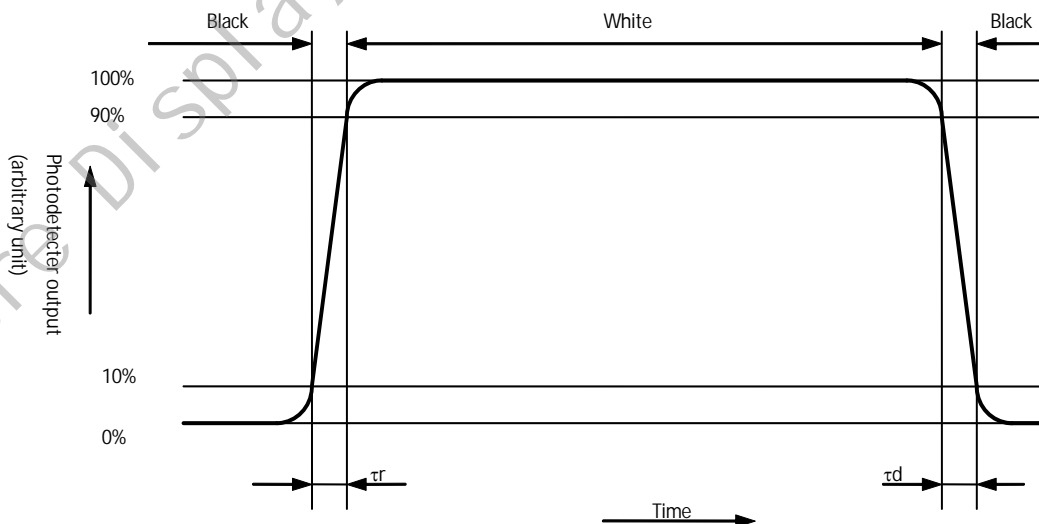

Fig. 10 Definition of response time

10. ReliabilityTable.15

No.	Test	Condition
1	High temperature storage test	Ta=70°C, 240h
2	Low temperature storage test	Ta=-30°C, 240h
3	High temperature Operation test	Ta=60°C, 240h
4	Low temperature Operation test	Ta=-20°C, 240h
5	Humidity Operation	Ta=40°C 95%RH, 240h
1	Heat shock test	Ta = -30°C(30min) to 70°C(30min), 20cycle
7	Electro static discharge test	±200V, 200pF(0Ω) to Terminals(Contact) (1 time for each terminals)

\* Ta=Ambient temperature

\*Check items for other test

In the standard condition, there shall be no practical problems that may affect the display function.

More Display Panels On [www.panoxdisplay.com](http://www.panoxdisplay.com)

## 11. Packaging specifications

### (11-1) Details of packaging

- 1) Packaging materials: Table.17
- 2) Packaging style : Fig. 11, 12

### (11-2) Reliability

#### 1) Vibration test

Table.16

Item	Test			
Frequency	5 Hz to 50 Hz (3 minutes cycle)			
Direction	Up-Down, Left-Right, Front-Back (3 directions)			
Period	Up-Down	Left-Right	Front-Back	Total
	60min	15min	15min	90min

The frequency should start at 5 Hz and vary continuously.

Total amplitude	20mm	0.2mm	20mm	0.2mm	
Frequency	5 Hz	50 Hz	5 Hz	50 Hz	(For 9.8m/s <sup>2</sup> )

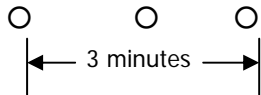

#### 2) Drop test

Drop height: 900mm  
 Number of drop: 10 times (Drop sequence: 1 corner, 3 edges, 6 faces)

### (11-3) Packaging quantities

240 modules per master carton

### (11-4) Packaging weight

About 12.1 kg



### (11-5) Packaging outline dimensions

365 mm × 580 mm × 279 mm (H)

(Packaging materials)

Table.17

	Parts name	Materials
1	Master carton	Corrugate card board
2	Inside sleeve	Corrugate card board
3	Outside sleeve	Corrugate card board
4	Tray for packaging	Polystyrene with anti-static treatment + anti-static polystyrene
5	Protective bag	Polyethylene with anti-static treatment
6	OPP tape	Polypropylene
7	Bar code label	Anti-static polyethylene

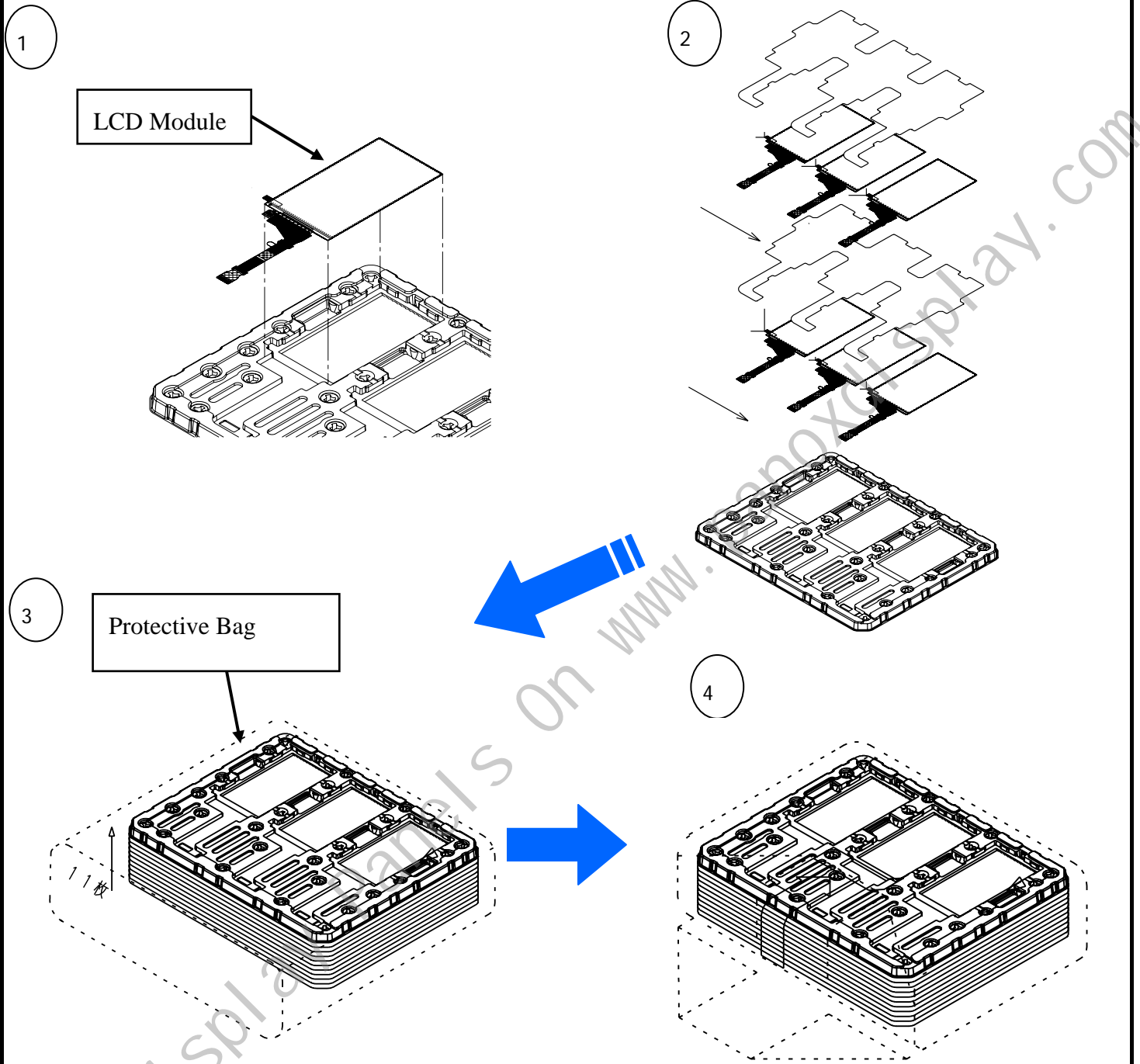
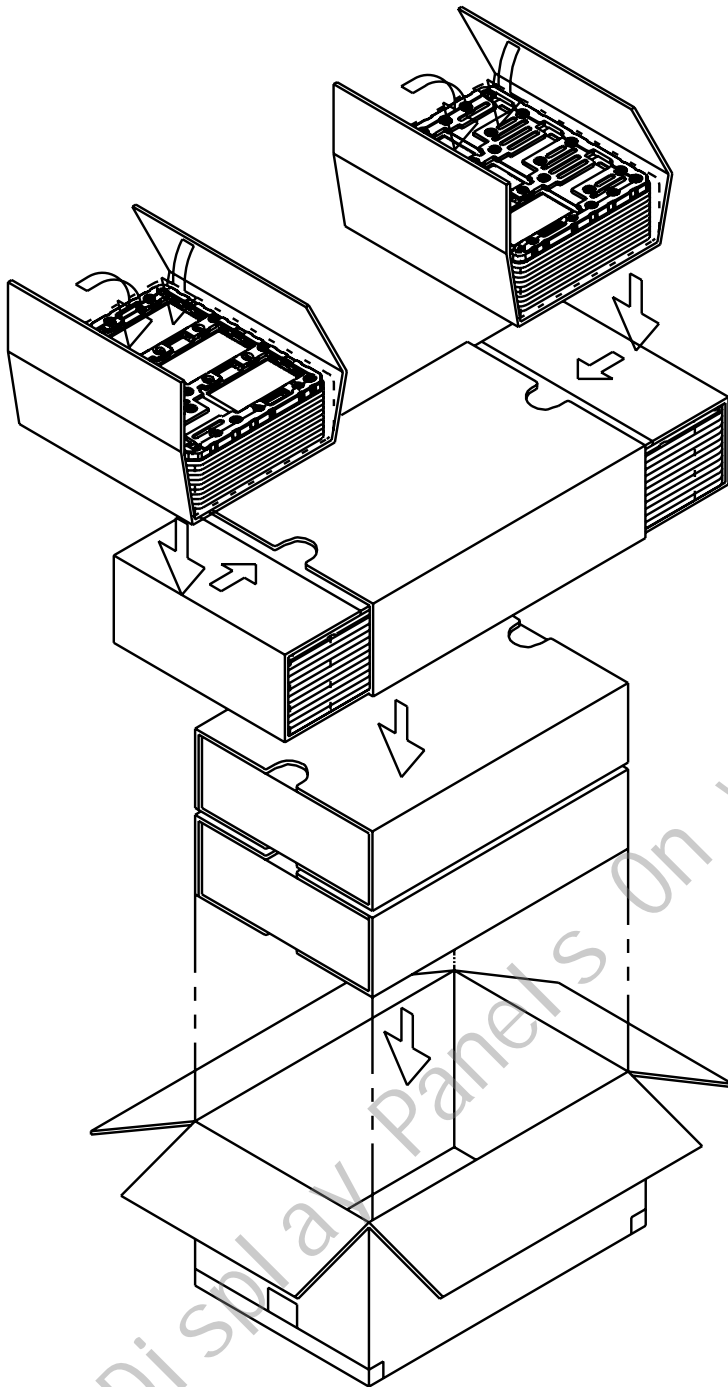

Fig.11 Packaging style (Tray for packaging)



社内品番 : (4S) LS055R1SX04
<input type="text"/>
LotNO. : (1T) 2014. xx. xx
<input type="text"/>
Quantity : (Q) 240 PCS
<input type="text"/>
ユーザー品番 : <input type="text"/>
シャープ物流用ラベルです。( ) ( )

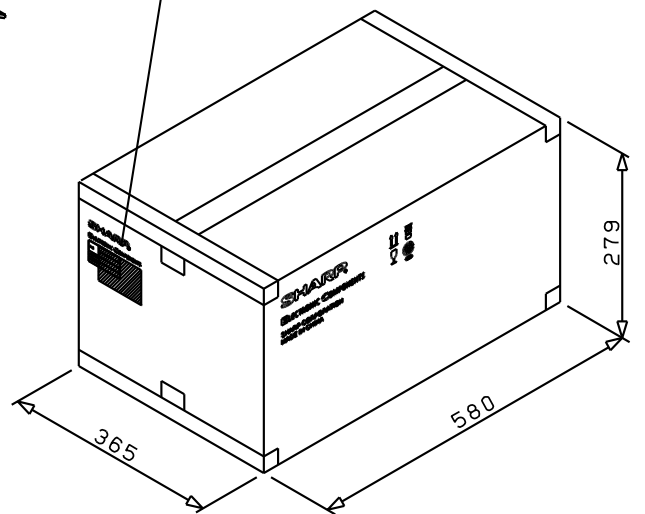

Fig. 12 Packaging style (Master carton for packaging)

## 12. Serial Number Label identification

Numbering is specified as follows.

04 4 6 000001 Q

①    ②    ③            ④            ⑤

① LCD module code : 04

② product year ( lower 1 digits )

4: 2014

5: 2015

③ product month

1: January

2: February

3: March

:

9: September

X: October

Y: November

Z: December

④ serial number

000001 ~ 999999

⑤ factory code

## 13. LCD Module Code Rule

LS 055 R 1 S X 04

①    ②    ③    ④    ⑤    ⑥    ⑦

① Parts type

CGS LCD

② Active area size

5.46inch

③ Dot format

WQHD    format

④ LCD type

Transmissive

⑤ Interface type

MIPI DSI 4 Lane, 2ports

⑥ Polarizer / LCD viewing type

Clear type / Wide viewing angle

⑦ Serial Code



## 14. Outline dimensions

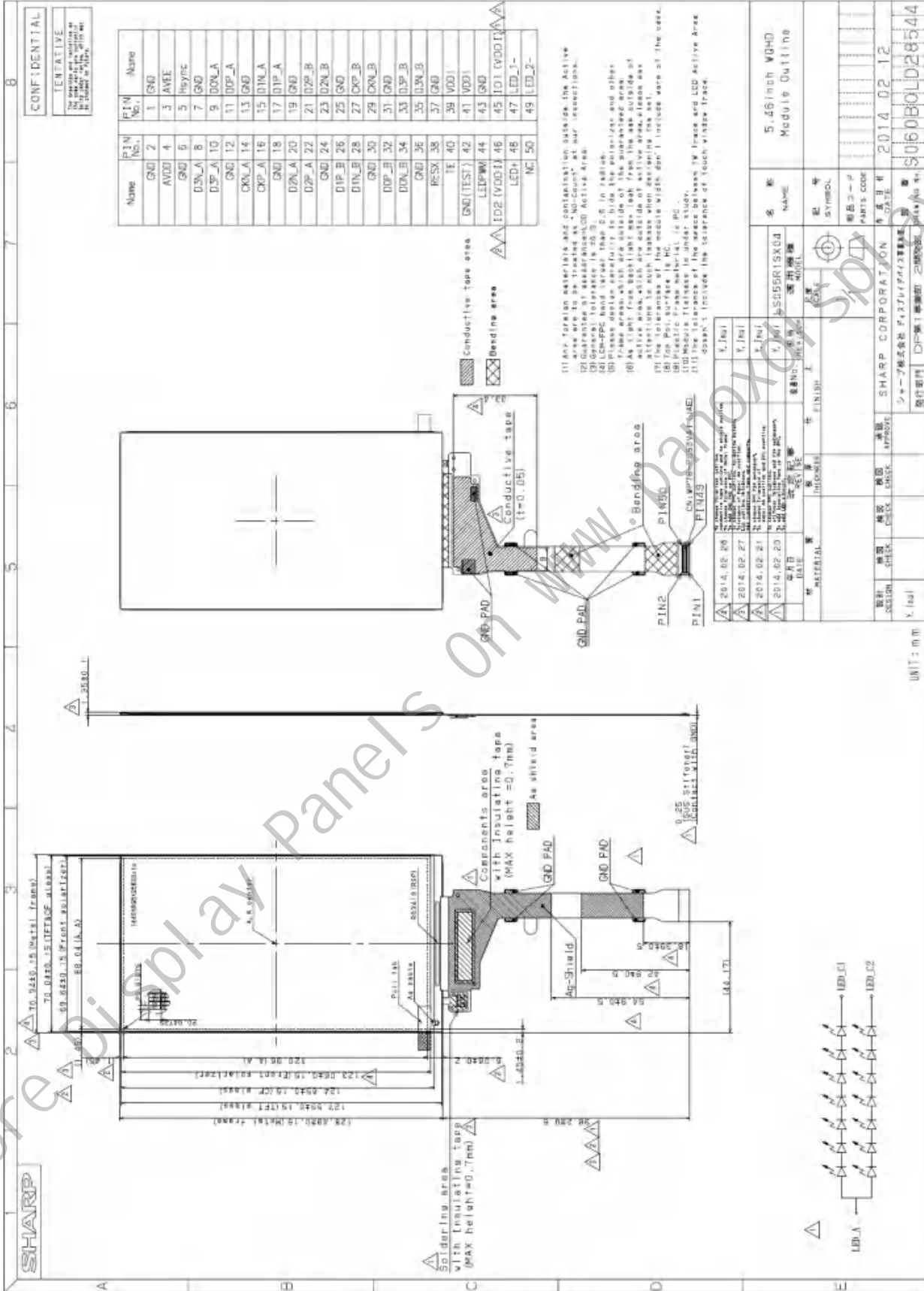

Fig. 13 Outline dimensions